

# DIAMANT FG3

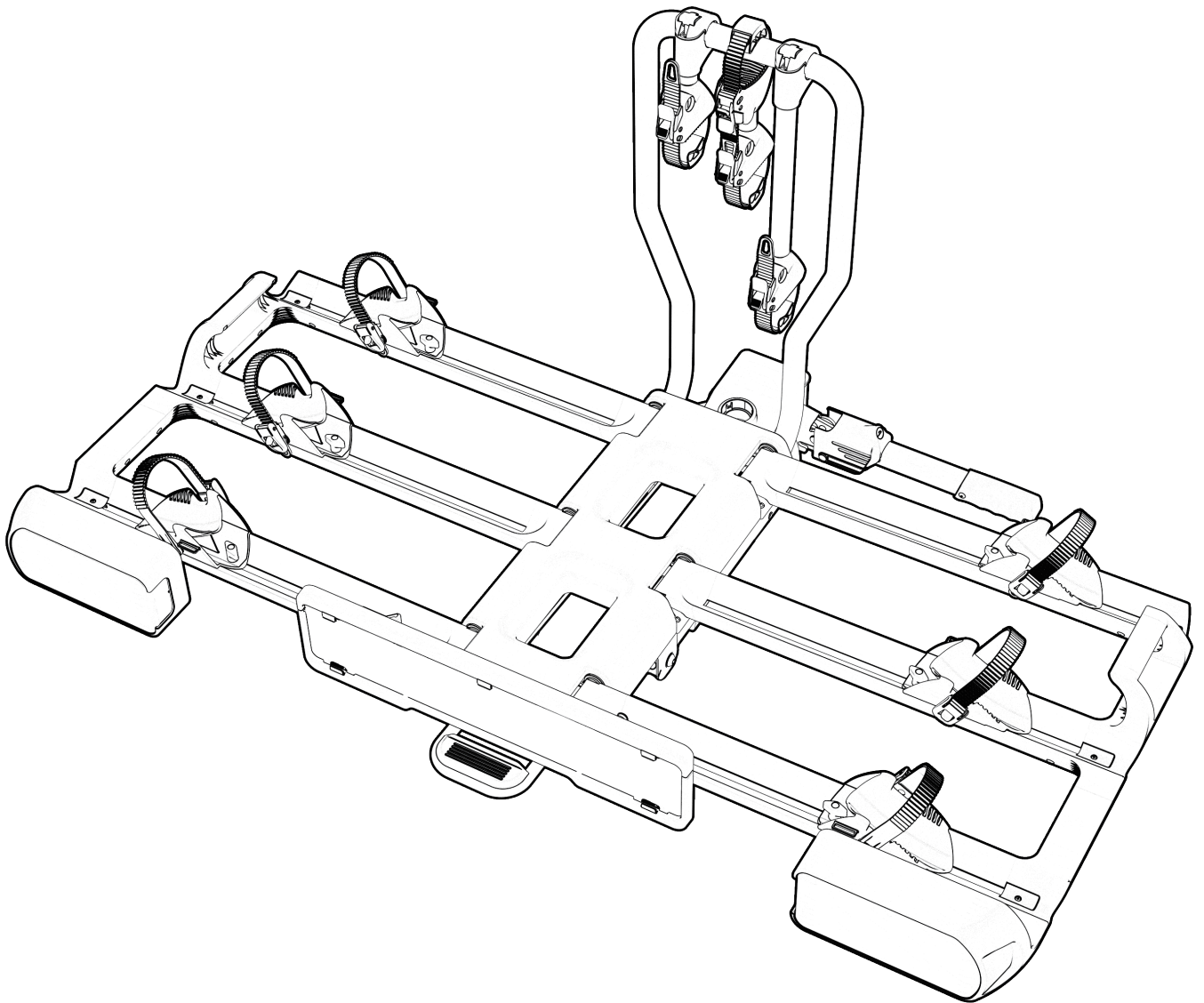

for full written manual  
scan QR-code or visit  
[www.pro-user.eu](http://www.pro-user.eu)



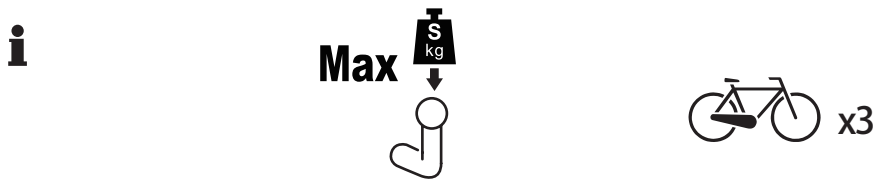
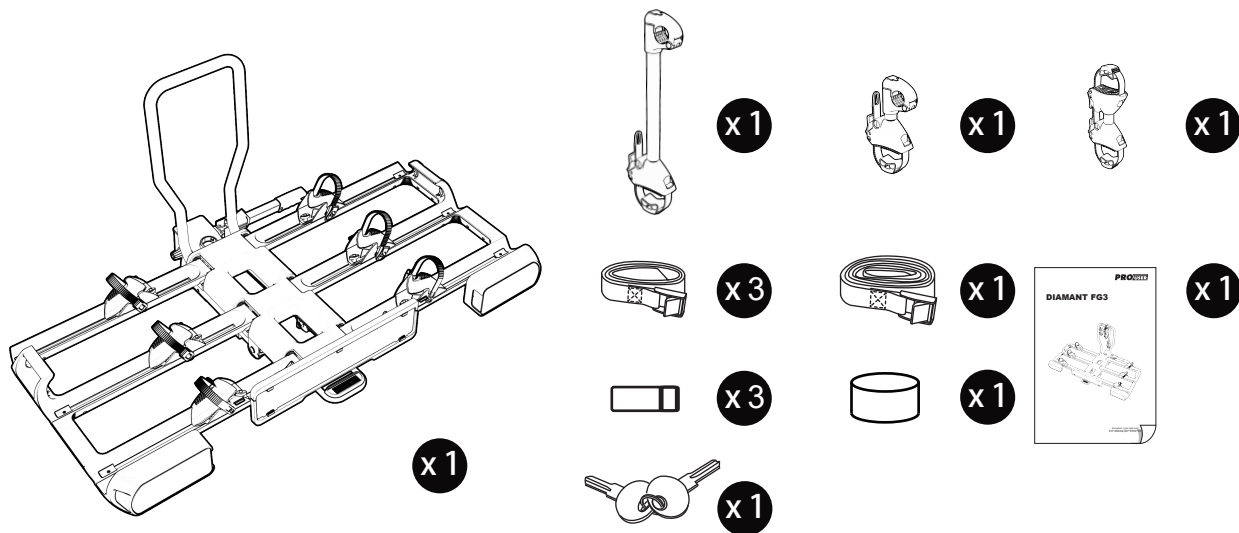

European type approval  
E4 26R-03 0465

# Scope of delivery



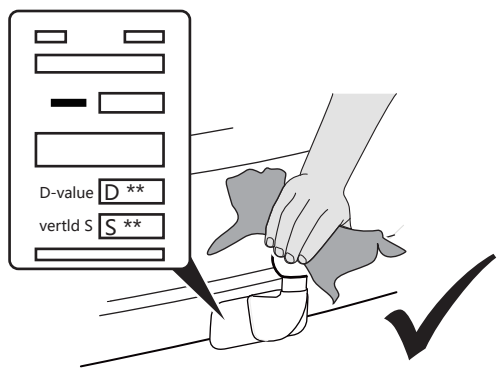

 22.3 kg	40 kg	Max 17.7 Kg
	50 kg	Max 27.7 Kg
	60 kg	Max 37.7 Kg
	75 kg	Max 52.7 Kg
	90 kg	Max 60 Kg ⚠
	120 kg	Max 60 Kg ⚠

	
Material:	min. steel St52 or grey cast iron GG52
D-value:	>7,6 kN
Tow ball:	ø50mm (class A-50 according EC 94/20 or ECE R55)



 Max. frame diameter : 110 mm

 Max. wheel base : 1350 mm

 Max. tire width : 80 mm



Max. 30kg per bike



Product weight



Max. load



Max. speed

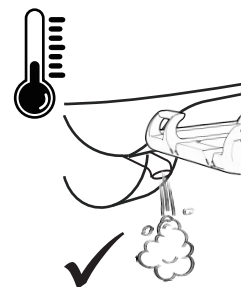
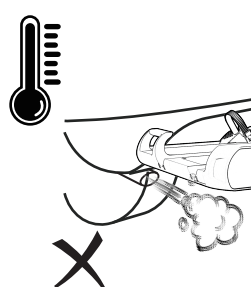
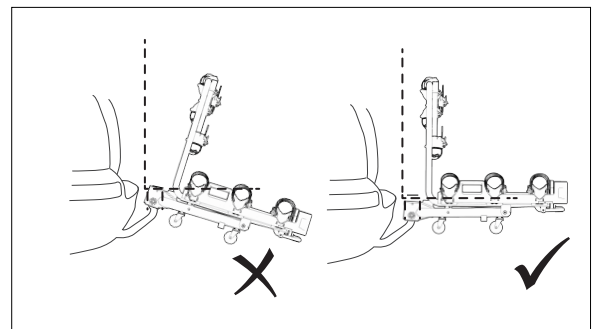
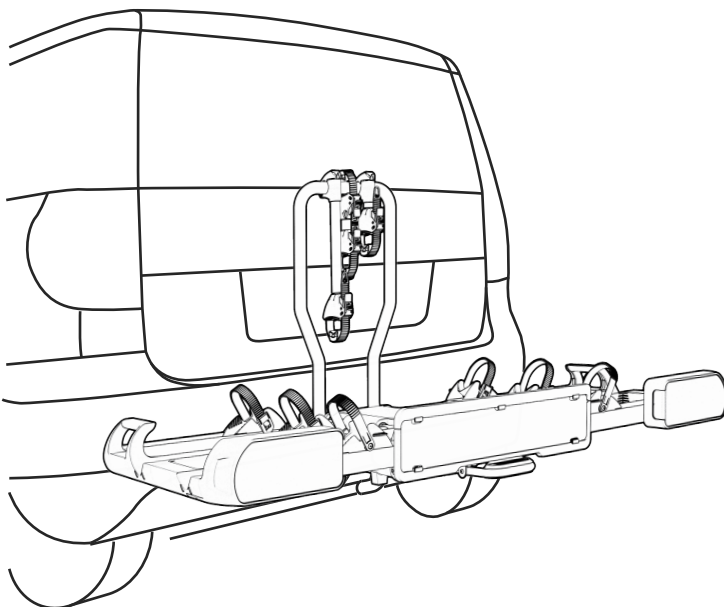
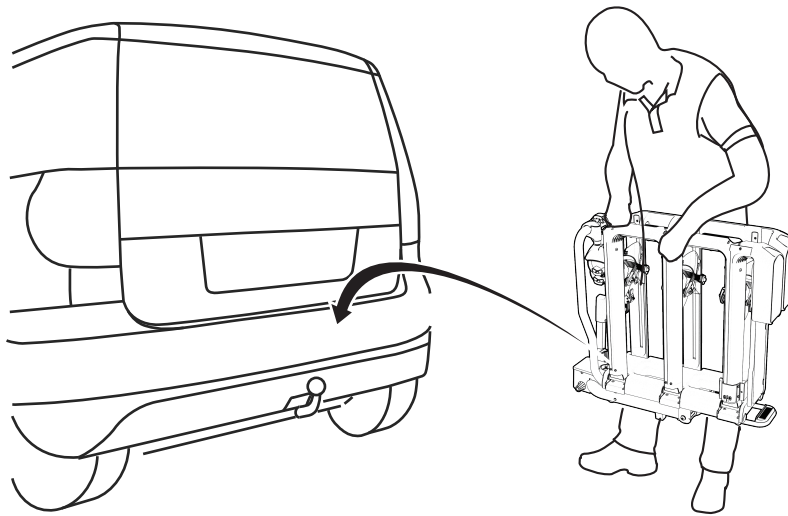

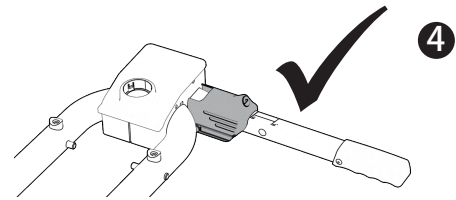
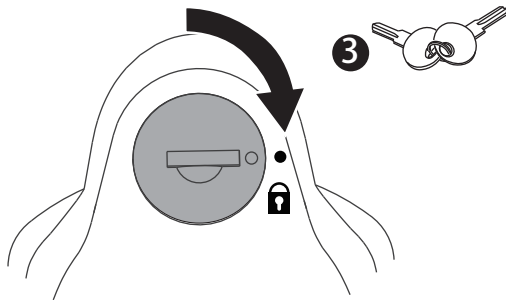
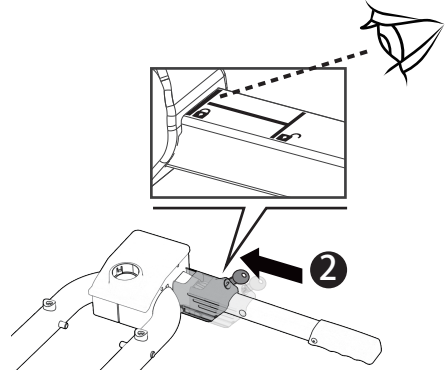
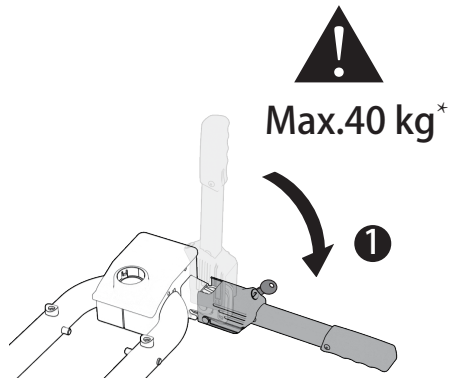

\* < 40 kg

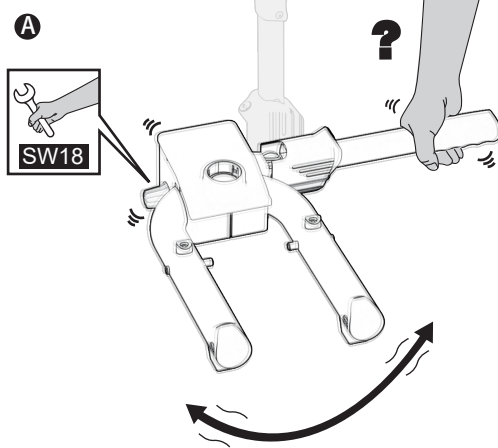

Not ok

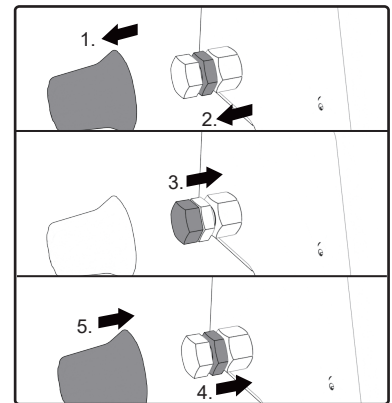

\* > 40 kg

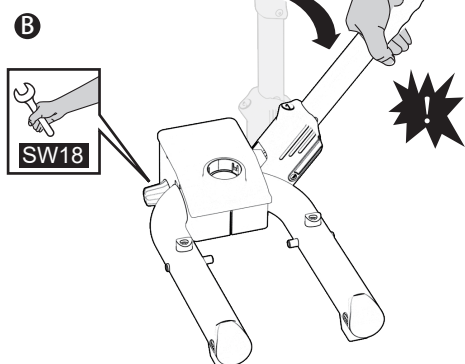

Not ok

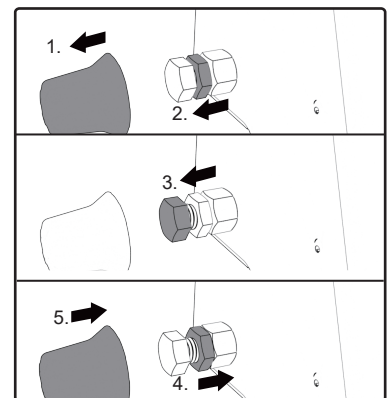

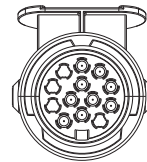
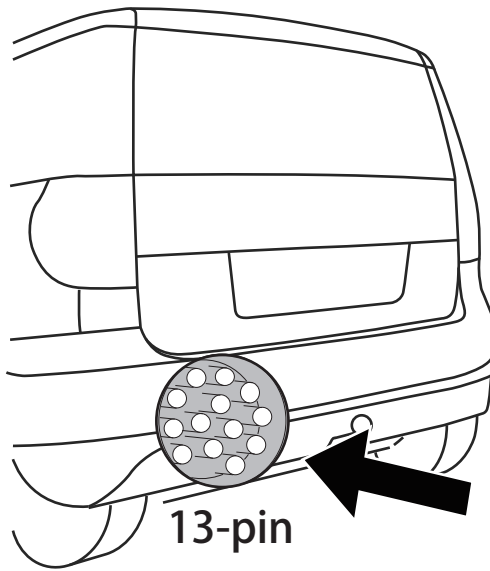
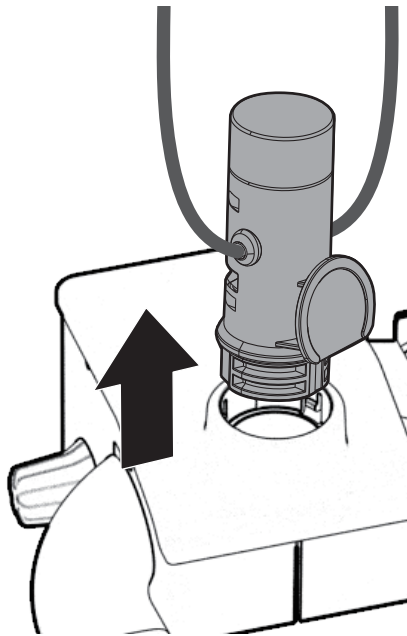

13-pin

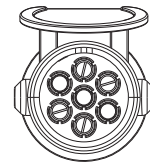
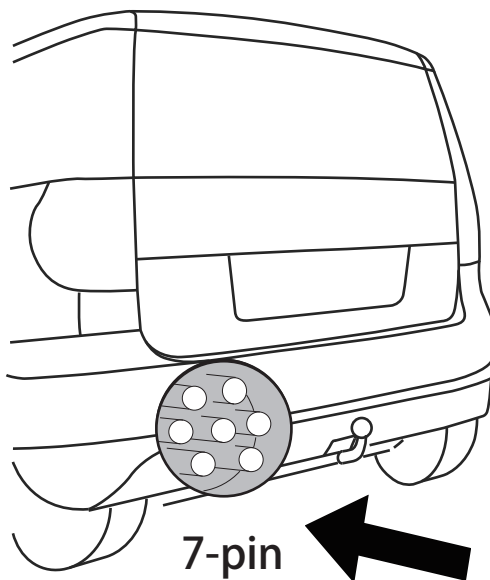
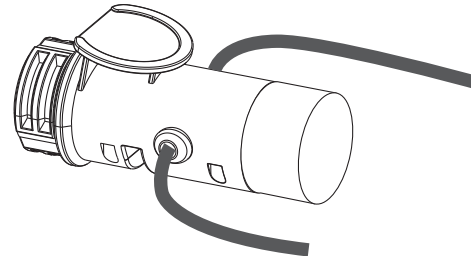

7-pin

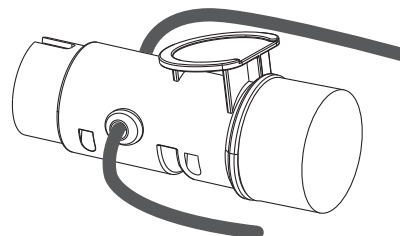

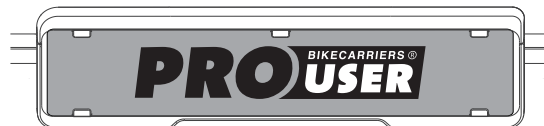
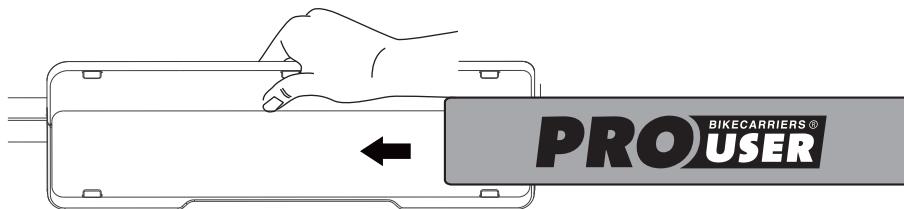
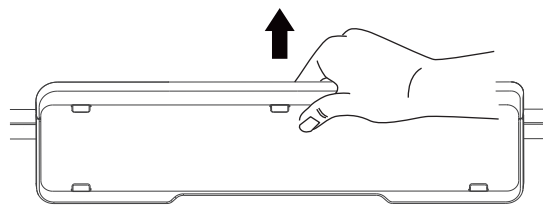
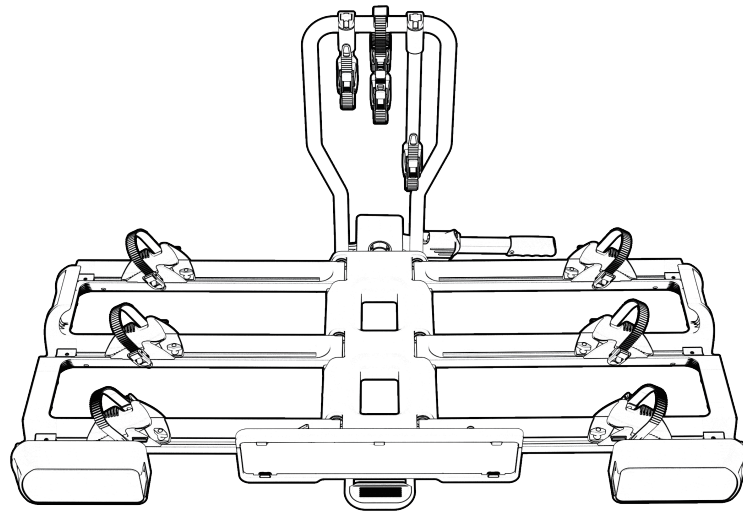
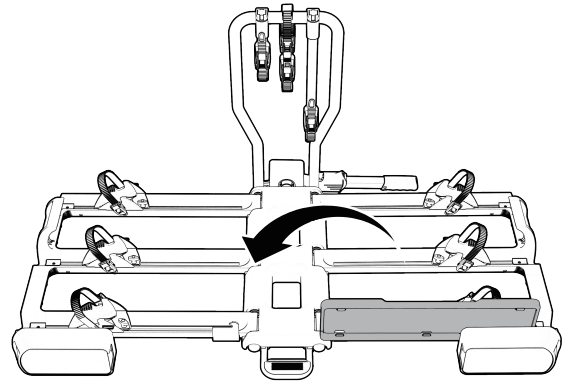
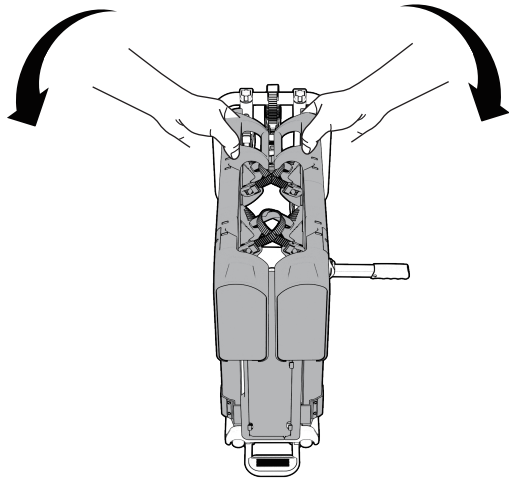

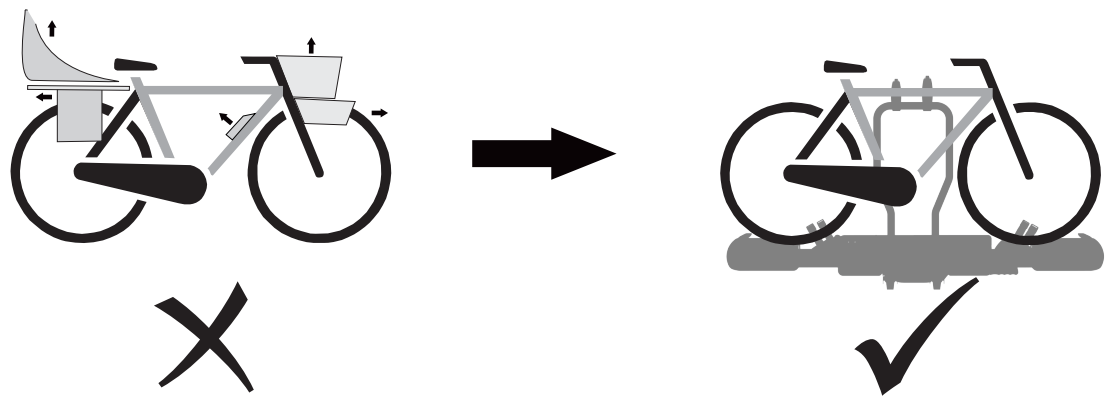
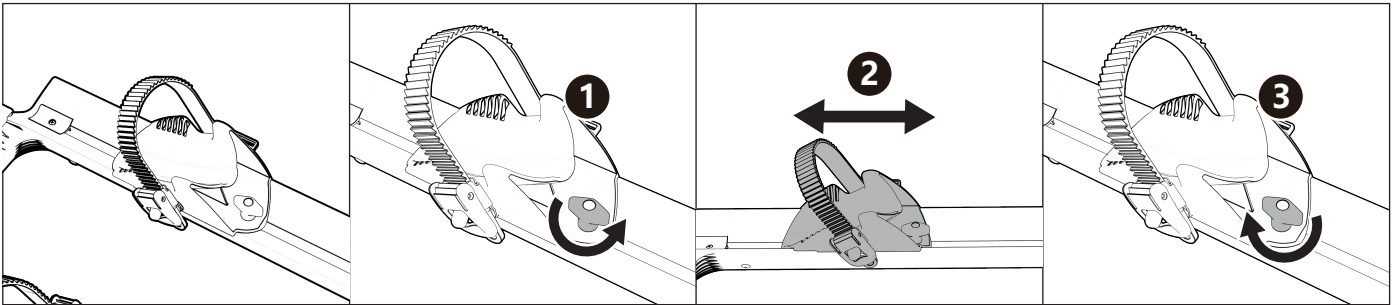
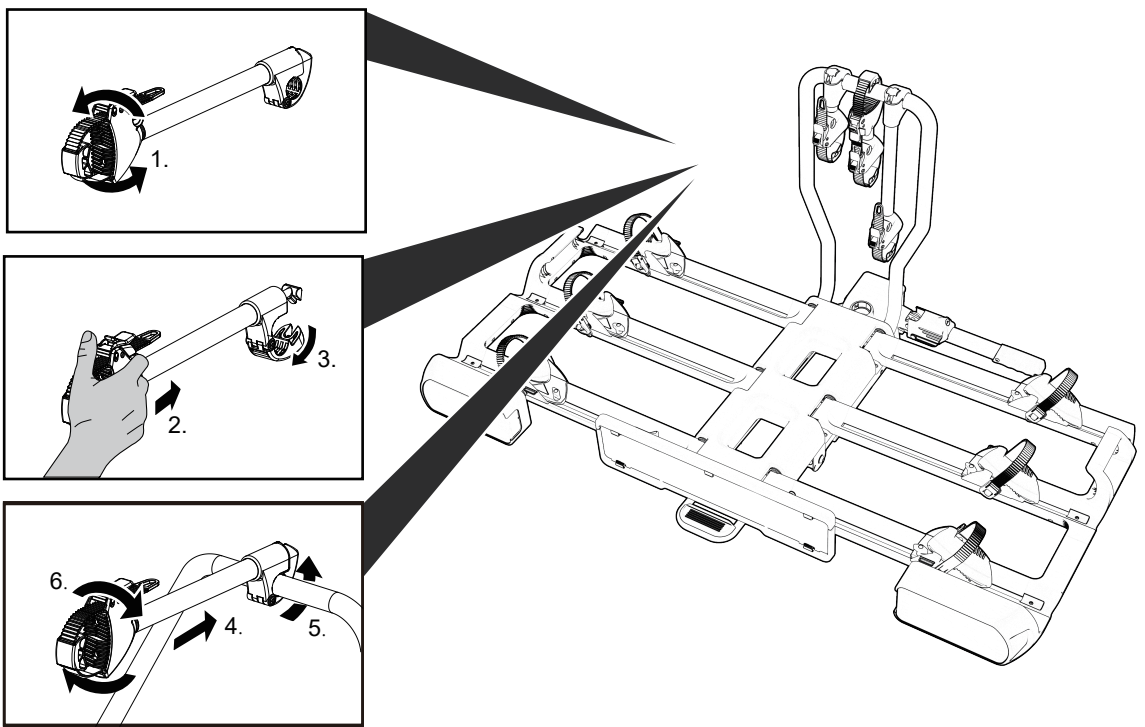
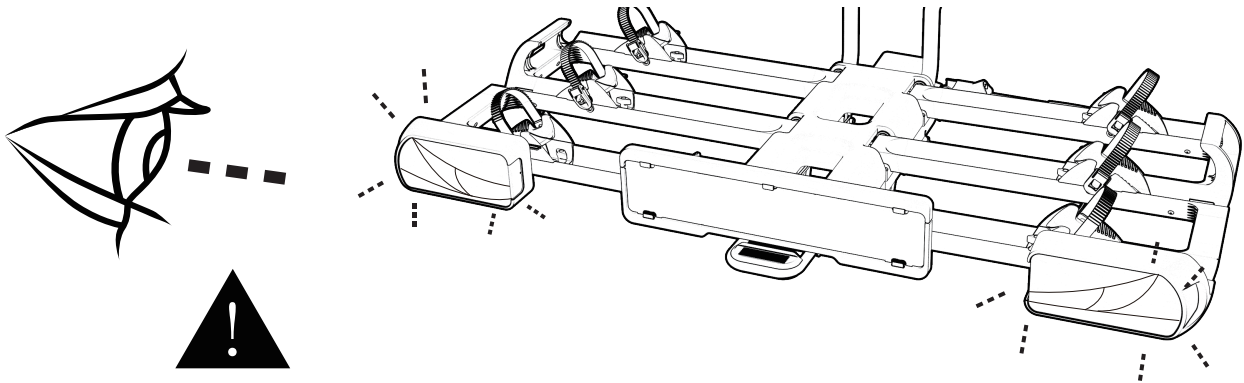

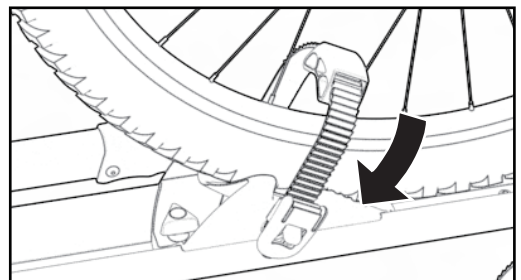
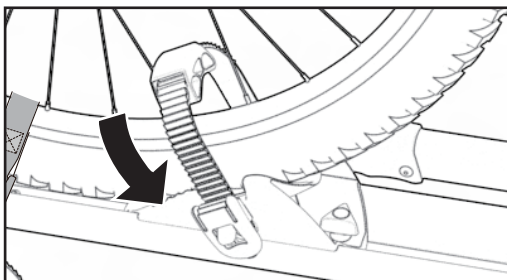
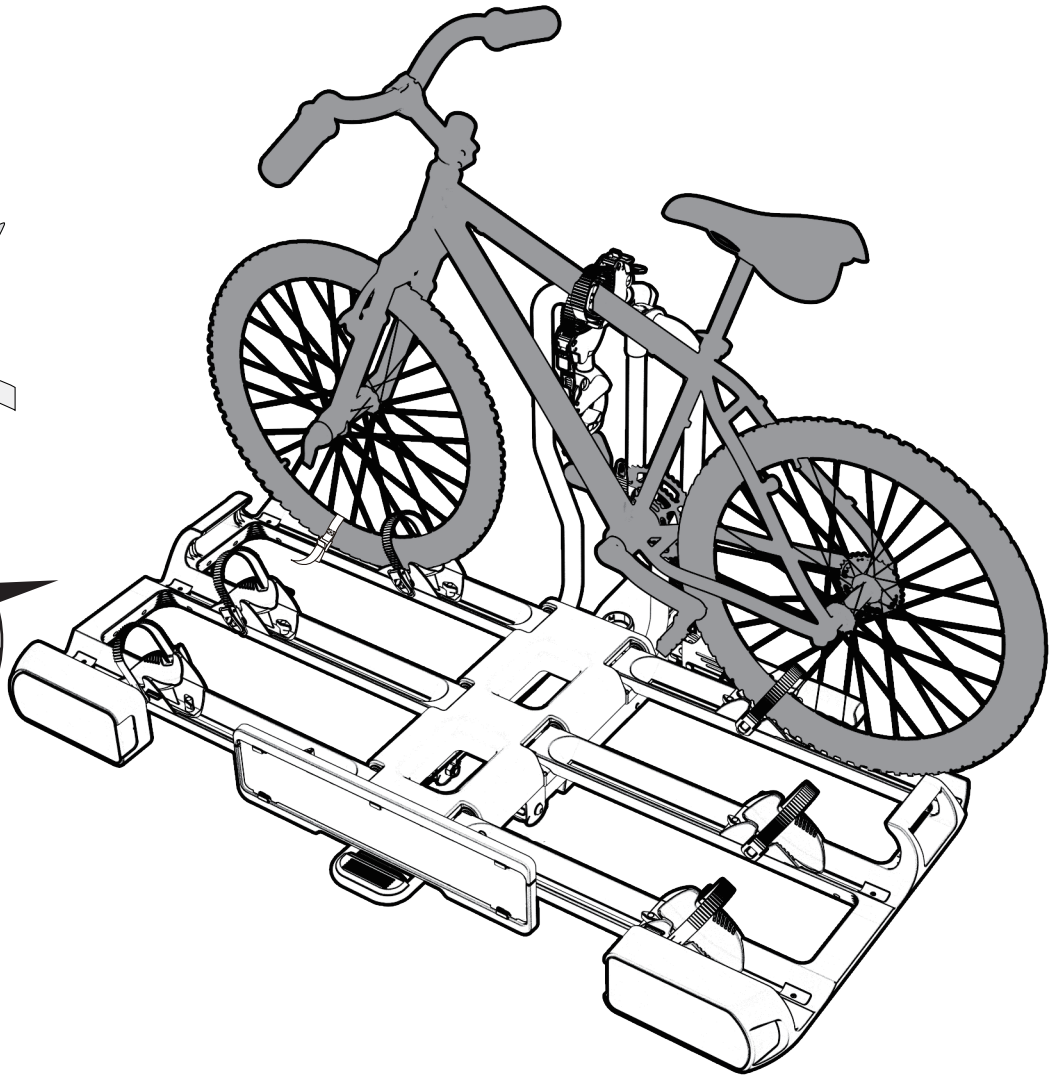
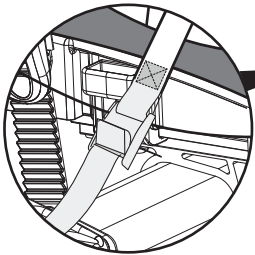
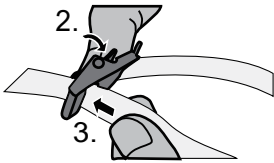
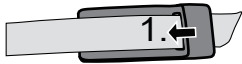
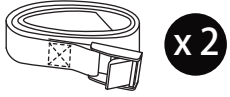
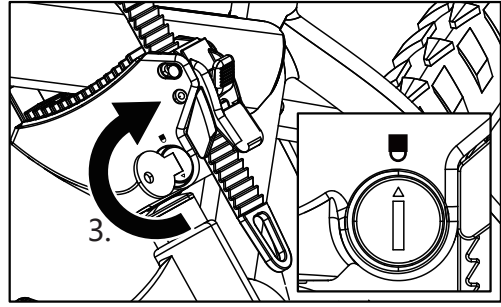
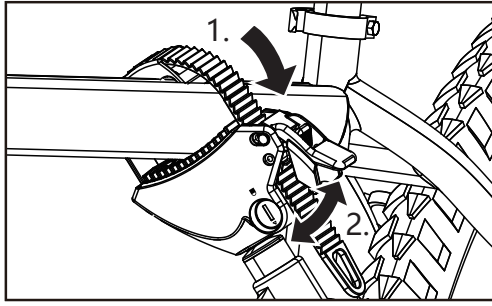



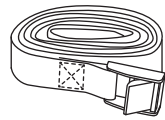
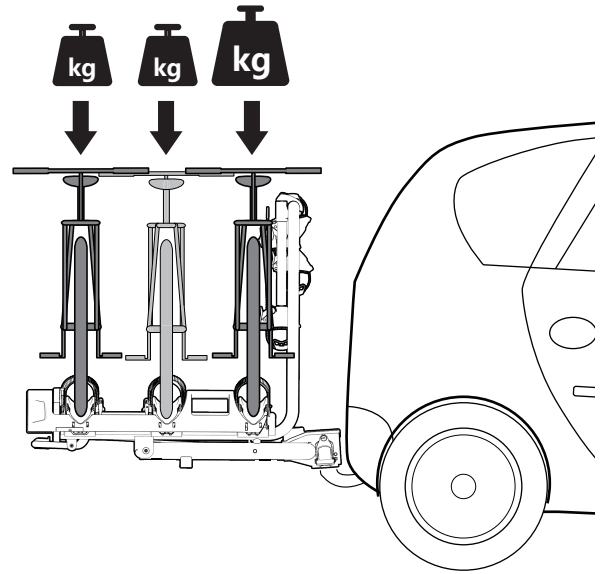
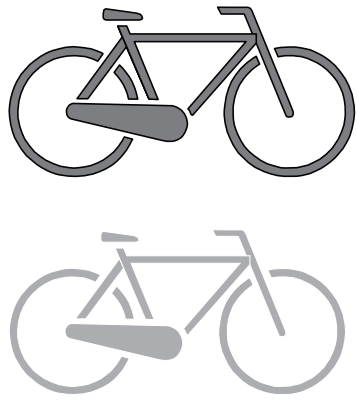

x 1

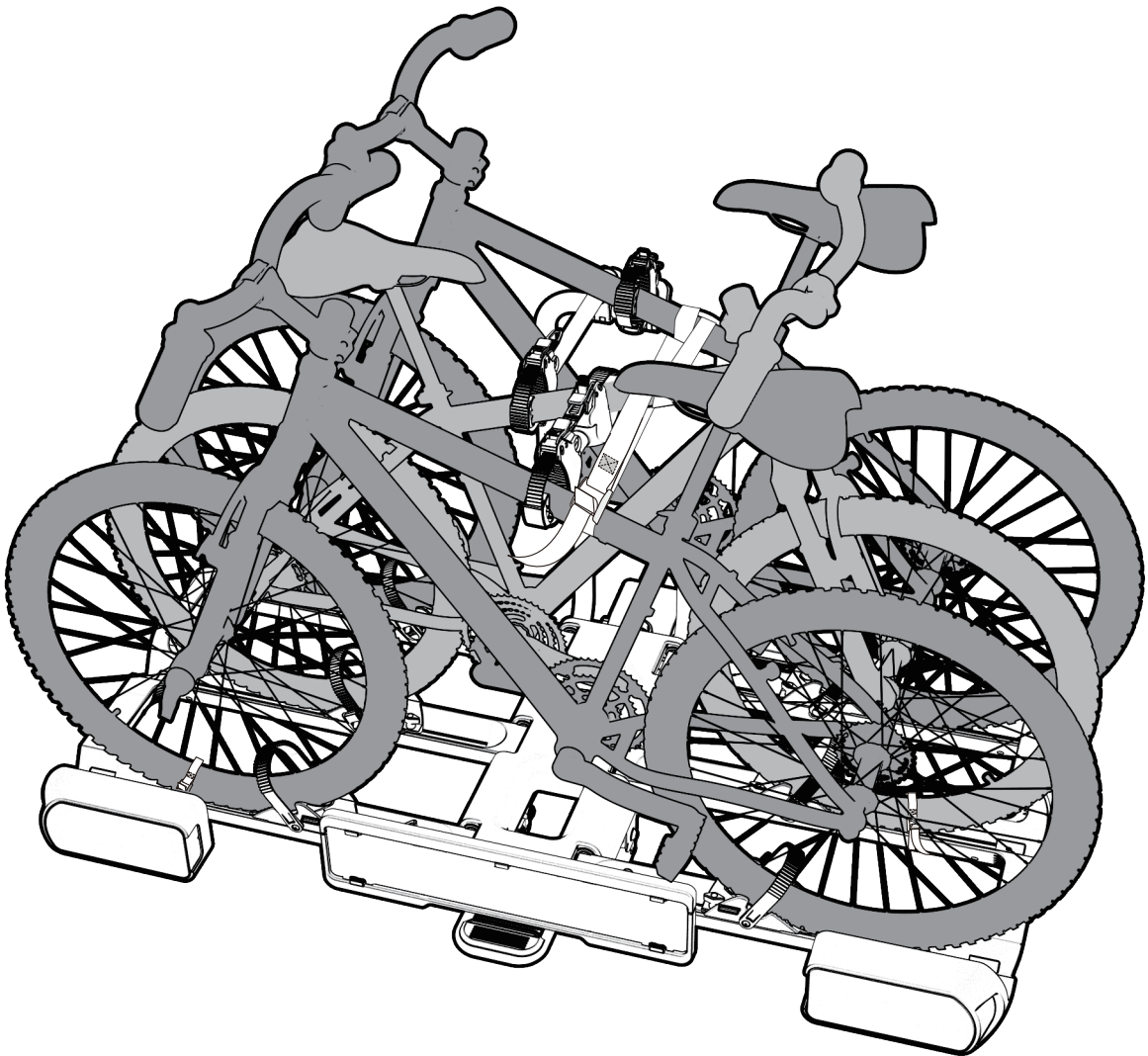

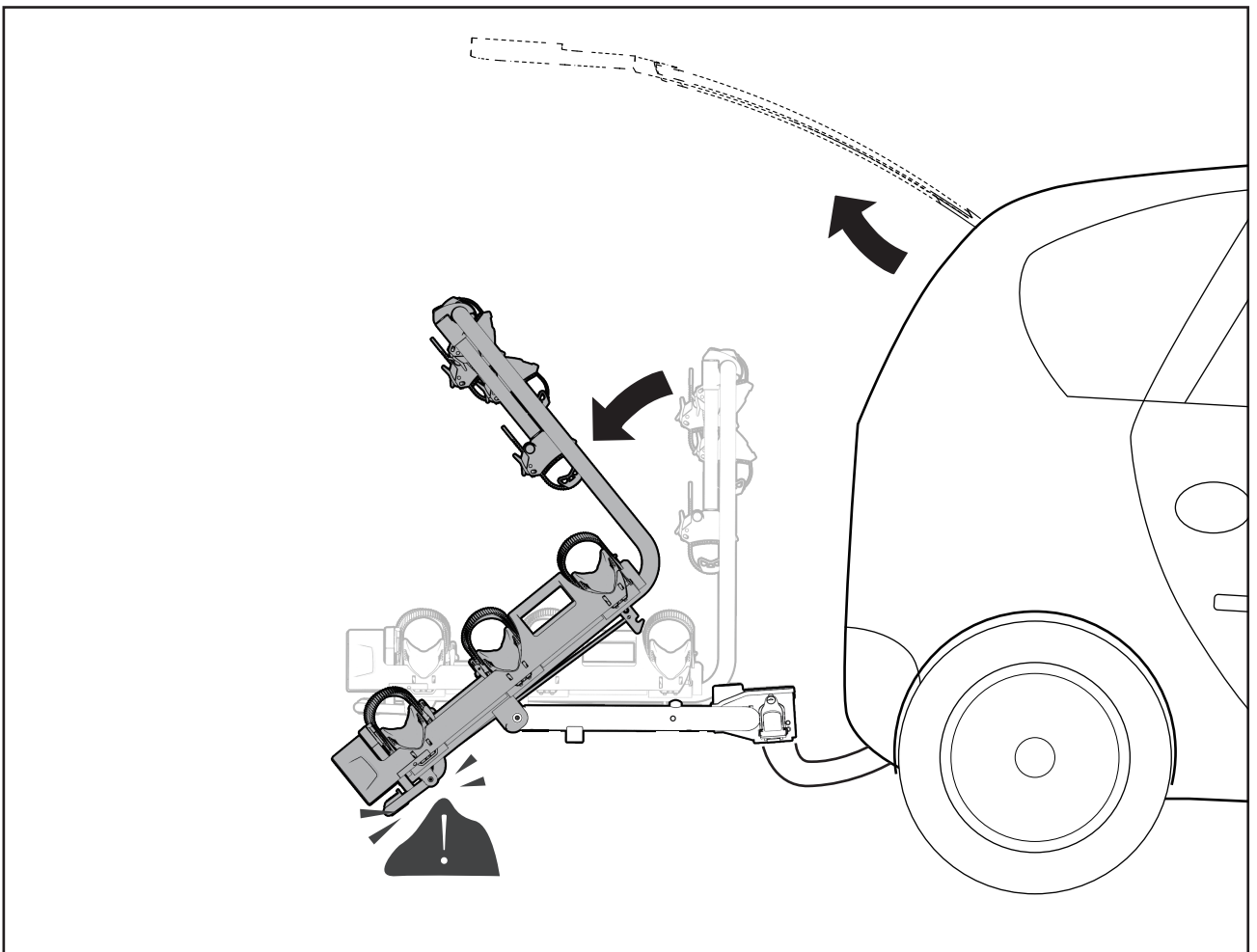
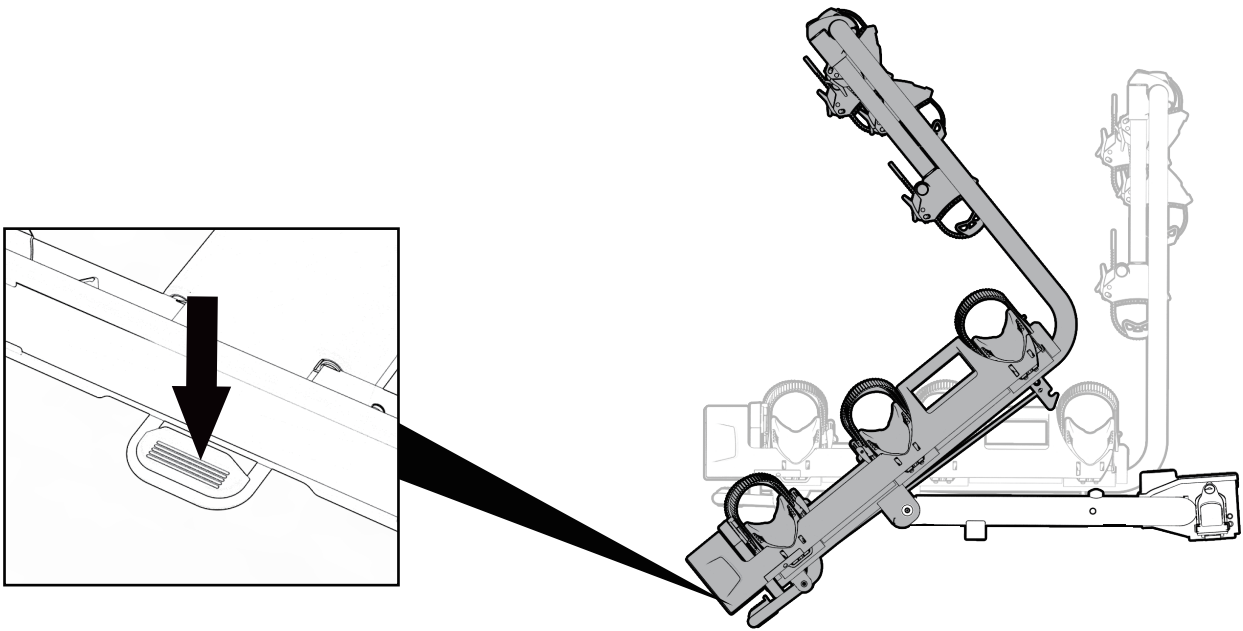

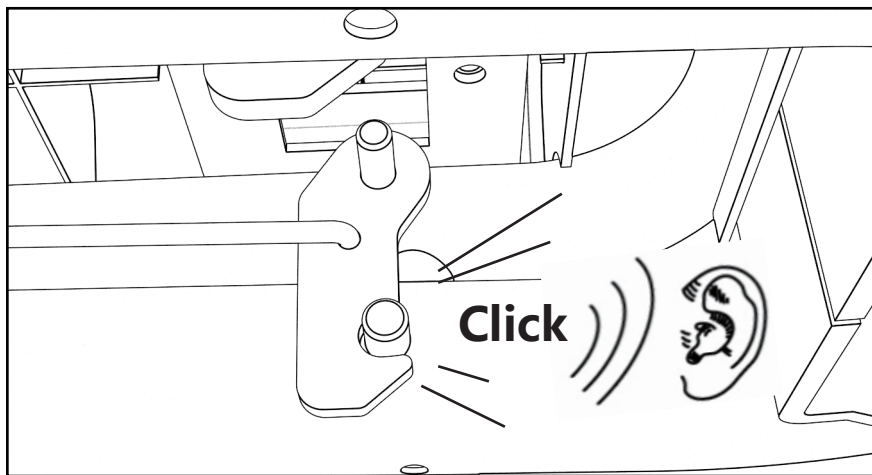
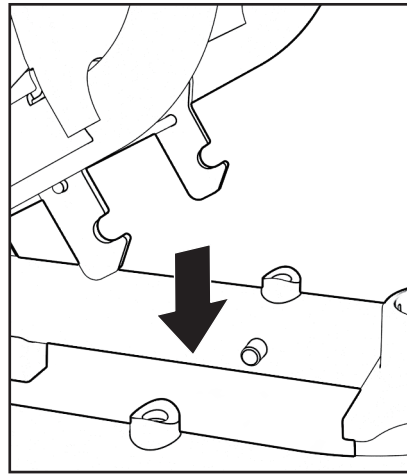
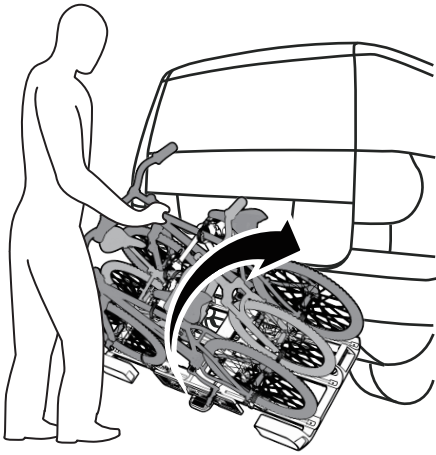
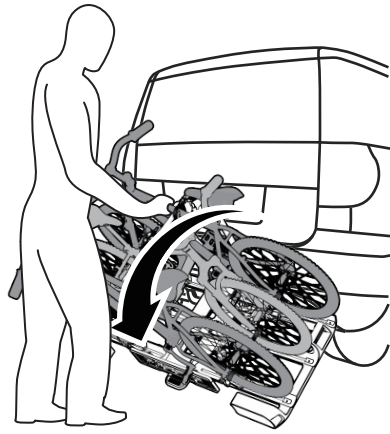
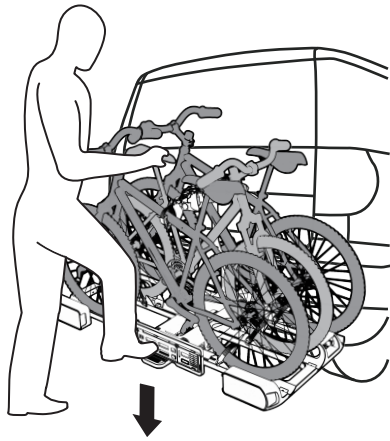

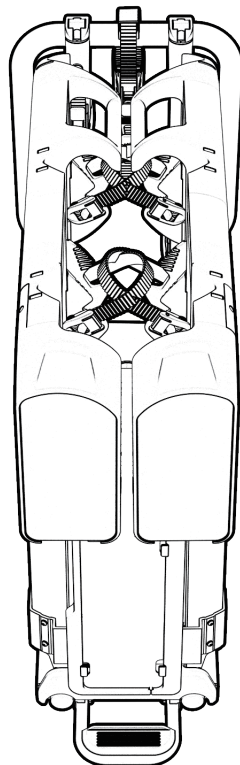
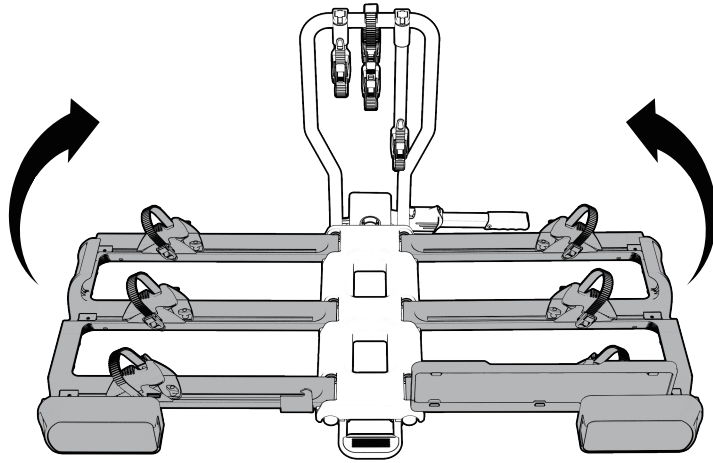
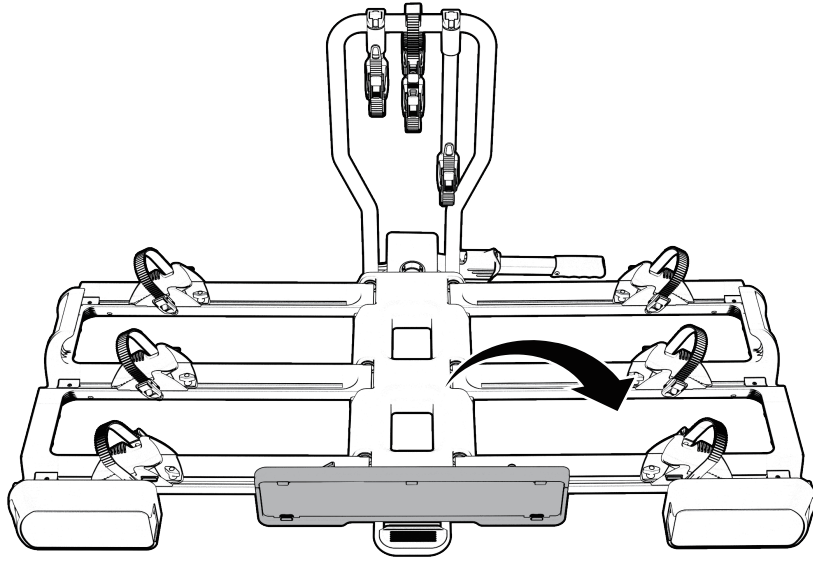

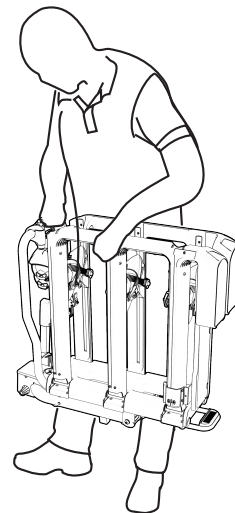
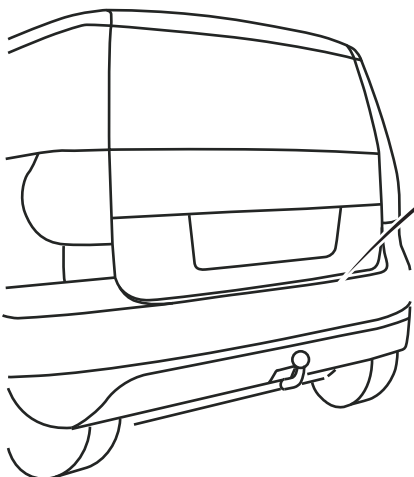
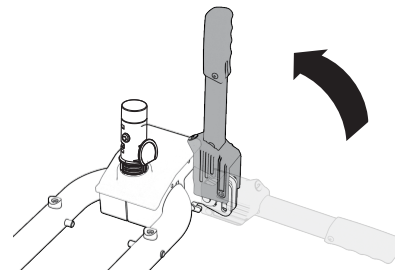
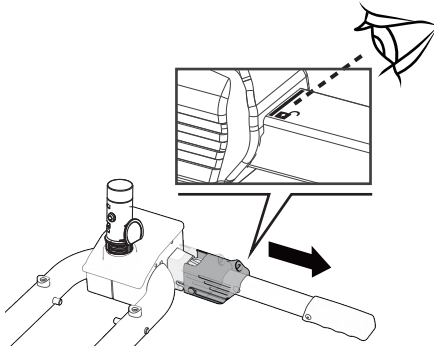
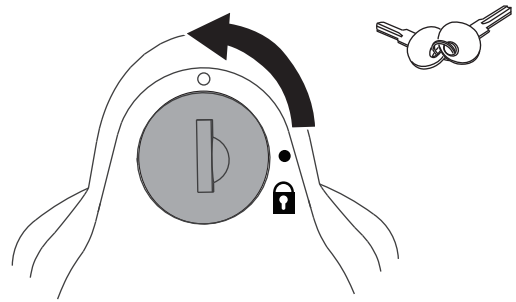
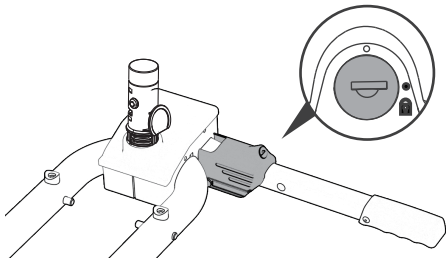
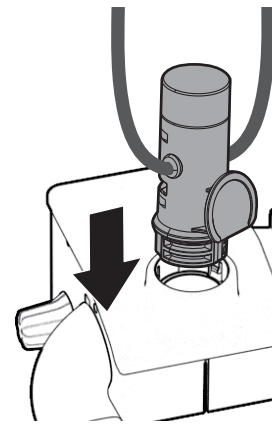
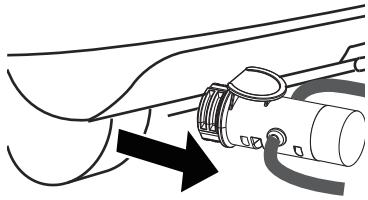

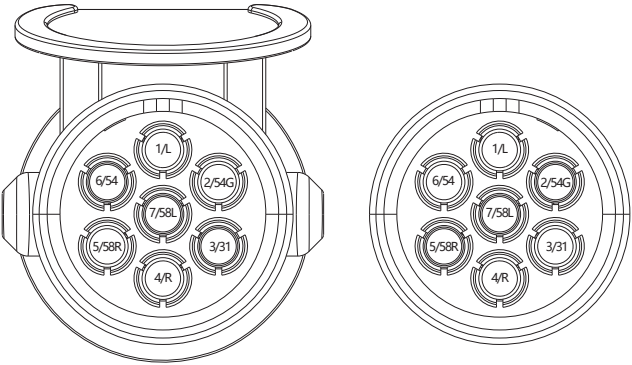
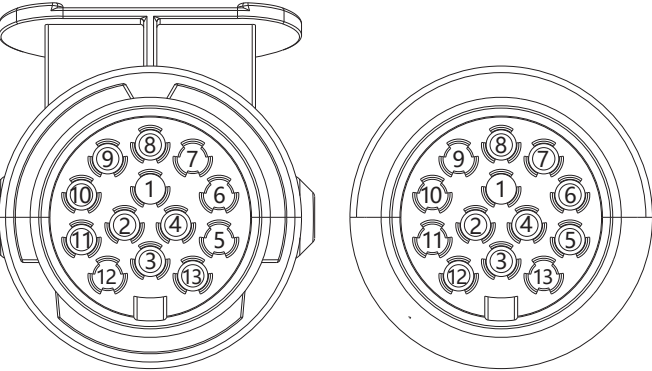
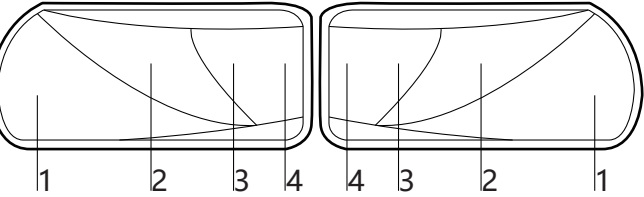
<p><b>Universal system 7 pin</b></p> 	<p>1/L 2/54G 3/31 4/R 5/58R 6/54 7/58L</p>	<p>Indicator left Rear fog light Ground Indicator right Rear light right Stop lights Rear light left</p> <p><b><i>The reversing light is not working via the 7-pin plug!</i></b></p>	<p>yellow blue white green brown red black</p>
<p><b>Jaeger system 13 pin</b> (DIN 72.570)</p> 	<p>1 2 3 4 5 6 7 8 9 10 11 12 13</p>	<p>Indicator left Rear fog light Ground Indicator right Rear light right Stop lights Rear light left Reversing light <i>Not used</i> <i>Not used</i> <i>Not used</i> Ground <i>Not used</i></p>	<p>yellow blue white green brown red black gray</p>
<p><b>12V Bulb</b></p> 	<p>1 2 3 4</p>	<p>12V 21/5W BAY15d 12V 21W BAY15d orange 12V 21W BAY15d 12V C5W</p>	

# Veiligheid en onderhoud fietsendragers

## Veiligheid

Volg nauwkeurig de instructies in de gebruiksaanwijzing. Niet opvolgen kan tot materiële schade, lichamelijk letsel of ernstige ongevallen leiden.

- Controleer voor iedere rit de goede staat en stevigheid van de fietsendrager en de gebruikte bevestigingsmaterialen (framehouders, wielstoppers en veiligheidsspanbanden). Defecte, beschadigde of versleten onderdelen of spanbanden moeten voor het begin van iedere rit worden vervangen.
- Monteer de fietsendrager niet als deze beschadigd is!
- Gebruik op de fietsen op de fietsendrager geen dekzeilen of andere soorten afdekking.
- Rijd langzaam over verkeersdrempels: max. snelheid 10km/h.
- Controleer de fietsendrager en de daarbij behorende lading regelmatig! U bent daartoe juridisch verplicht en u wordt in geval van schade aansprakelijk gesteld!

Tradekar Benelux B.V. aanvaardt geen enkele aansprakelijkheid voor schade veroorzaakt door oneigenlijk gebruik of misbruik van de fietsendrager.

## Onderhoud

Onder normale omstandigheden is de fietsendrager onderhoudsvrij. Indien van de fietsendrager in het kustgebied of tijdens de winter (pekel) gebruik wordt gemaakt, maak deze dan regelmatig schoon. De fietsendrager kan met een zacht wasmiddel, lauwwarm water en/of een zachte doek worden schoongemaakt. Laat de fietsendrager zelf opdrogen. Bewaar de fietsendrager droog en afgedekt, om de levensduur te verlengen.

De stalen onderdelen in de fabriek van een poedercoating voorzien om corrosie tegen te gaan. Als deze beschermlaag is beschadigd, dan dient de schade zo snel mogelijk op professionele wijze te worden hersteld.

Elke wijziging aan originele onderdelen, materialen of aan de constructie kunnen de veiligheid en effectief gebruik van de fietsendrager nadelig beïnvloeden.

Neem bij vragen en voor de vervanging van onderdelen contact op met de klantenservice van Tradekar Benelux B.V.

## **HELPDESK & SUPPORT**

 +31 (0)345-470998 (maandag t/m vrijdag 8:30-12:30 uur)

 [service@tradekar.com](mailto:service@tradekar.com)

# Safety and maintenance bicycle carriers

## Safety

Follow the instructions in the user manual carefully. Failure to follow may result in property damage, personal injury or serious accidents.

- Before every ride, check the good condition and sturdiness of the bicycle carrier and the mounting materials used (frame holders, wheel stoppers and safety straps). Defective, damaged or worn parts or straps must be replaced before each ride.
- Do not mount the bicycle carrier if it is damaged!
- Do not use tarpaulins or other types of cover on the bicycles on the bicycle carrier.
- Drive slowly over speed bumps: max. speed 10km/h.
- Regularly check the bicycle carrier and the associated load! You are legally obliged to do so and you will be liable in case of damage!

Tradekar Benelux B.V. accepts no liability for damage caused by improper use or misuse of the bicycle carrier.

## Maintenance

Under normal circumstances, the bicycle carrier is maintenance-free. If the bicycle carrier is used in the coastal area or during the winter (brine), clean it regularly. The bicycle carrier can be cleaned with a mild detergent, lukewarm water and/or a soft cloth. Let the bicycle carrier dry itself. Store the bicycle carrier dry and covered to prolong its life.

Steel parts are powder coated at the factory to prevent corrosion. If this protective layer is damaged, the damage must be repaired professionally as soon as possible.

Any changes to original parts, materials or construction may adversely affect the safety and effective use of the bicycle carrier.

If you have any questions or need parts to be replaced, please contact the Tradekar Benelux B.V. customer service.

## **HELPDESK & SUPPORT**

 +31 (0)345-470998 (Monday to Friday 8:30 am-12:30 pm)

 [service@tradekar.com](mailto:service@tradekar.com)

© Tradekar 91764/24A

**PRO** BIKE CARRIERS®  
**USER**

**Tradekar Benelux BV**

Ohmweg 1  
4104 BM CULEMBORG  
The Netherlands

+31 (0)345-470990  
info@tradekar.com  
www.pro-user.eu

